



EMERGENCY 2

Product Code: EM02.XX.XXX.XX

Product description:

The Emergency 2 is a high performance self-contained LED emergency luminaire. It incorporates an LED module, an NiMH battery pack and a deep discharge protection circuit. The unit can be surface mounted or recessed into a 105mm – 110mm cut out using mounting brackets provided. The luminaire includes a rechargeable 3.6V 1.7Ah NiMH battery pack for 3 hours operation. The in-built reflector design ensures efficient output. Includes integral charge indicator LED.

5 YEAR
GUARANTEE

Product options	For exact specifications create a Project Datasheet
Dimensions (mm):	120 (D) x 44 (H)
Cut-out (mm):	105 (D)
Lifetime:	50,000 hrs
Mounting type:	Surface Mounted
Finish:	Matt White, Matt Black
Emergency:	3-hour integrated battery

Cross-section

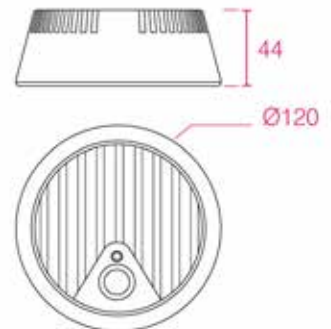

Lighting options	For exact specifications create a Project Datasheet
Light source:	High performance 3W LED
Driver:	Fixed Output, DALI
Colour temperature:	-
Beam angle:	40°
Diffuser:	-
Operating voltage:	230V
IP Rating:	IP20
CRI:	-
Delivered Lumens (lm):	130
Power consumption (W):	3.4
Efficiency (lm/W):	38.2
Optional Extras:	Auto-test, DALI or Central Battery technology compatibility

Photometrics

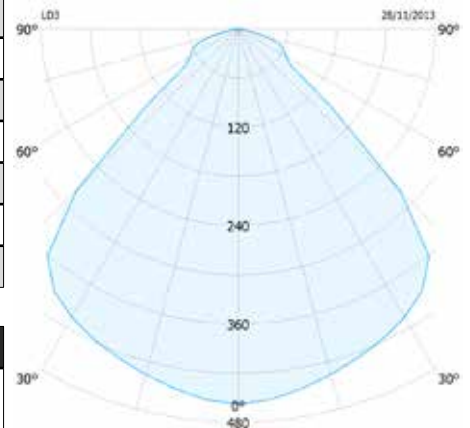

Additional Info
Also available as a recessed solution

