

ATTENTION: POUR TOUTE INTERVENTION SUR L'APPLIQUE, COUPER L'ALIMENTATION.

CAREFUL: FOR THIS OPERATION YOU HAVE TO CUT OFF THE POWER.

ACHTUNG: FÜR DIESE HAND HABUNG MUB DER STROM UNTERBROCHEN.

CUIDADO: PARA CUALQUIER INTERVENCIÓN EN EL APLIQUE, CORTAR LA ALIMENTACIÓN ELÉCTRICA.

ATTENZIONE: PER QUELUNQUE INTERVENTO SULL'APPLIQUE INTERRUPERE L'ALIMENTAZIONE ELETTRICA.

	Luminaire Classe 3	Luminaire Classe 3	Luminaire Classe 2	Class 2 lamp
3071	Type de lampe: Halogène à réflecteur dichroïque 50W / GX5.3	Bulb type: Halogen with dichroitic reflector 50W / GX5.3	Type de lampe: Halogène GU10 / LED 50W-GU10/ 9W-LED	Bulb type: Halogen GU10 / LED 50W-GU10/ 9W-LED
3072	Type de lampe: Halogène à réflecteur dichroïque 2 x 50W / GX5.3	Bulb type: Halogen with dichroitic reflector 2 x 50W / GX5.3	Type de lampe: Halogène GU10 / LED 2x50W-GU10/ 2x9W-LED	Bulb type: Halogen GU10 / LED 2x50W-GU10/ 2x9W-LED
3073	Type de lampe: Halogène à réflecteur dichroïque 3 x 50W / GX5.3	Bulb type: Halogen with dichroitic reflector 3 x 50W / GX5.3	Type de lampe: Halogène GU10 / LED 3x50W-GU10/ 3x9W-LED	Bulb type: Halogen GU10 / LED 3x50W-GU10/ 3x9W-LED

atelier sedap

1

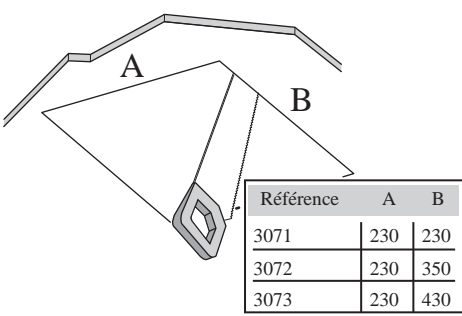

Référence	A	B
3071	230	230
3072	230	350
3073	230	430

2

Le câble d'alimentation doit supporter une T° de 105°C minimum.
The mains wire must support a T° of 105°C minimum.

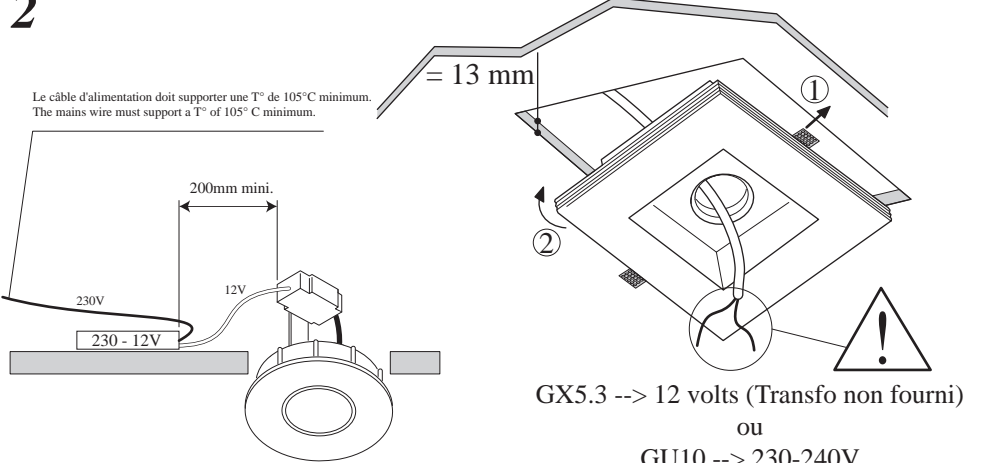

GX5.3 --> 12 volts (Transfo non fourni)
ou
GU10 --> 230-240V

3

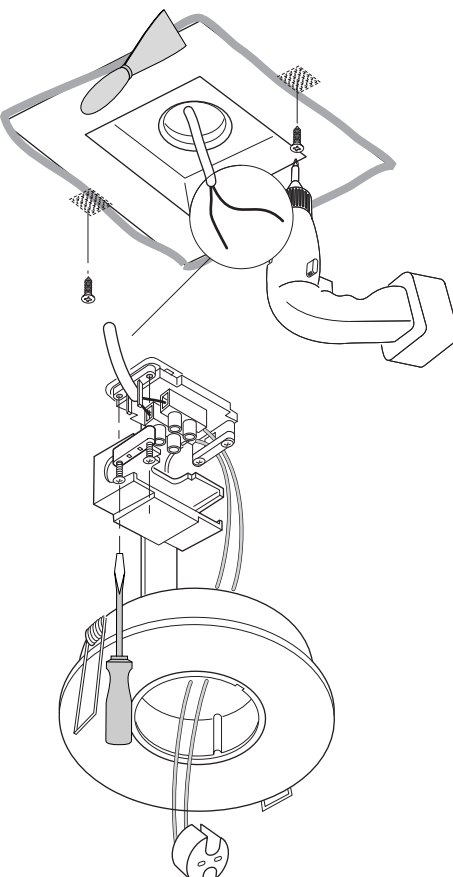

4

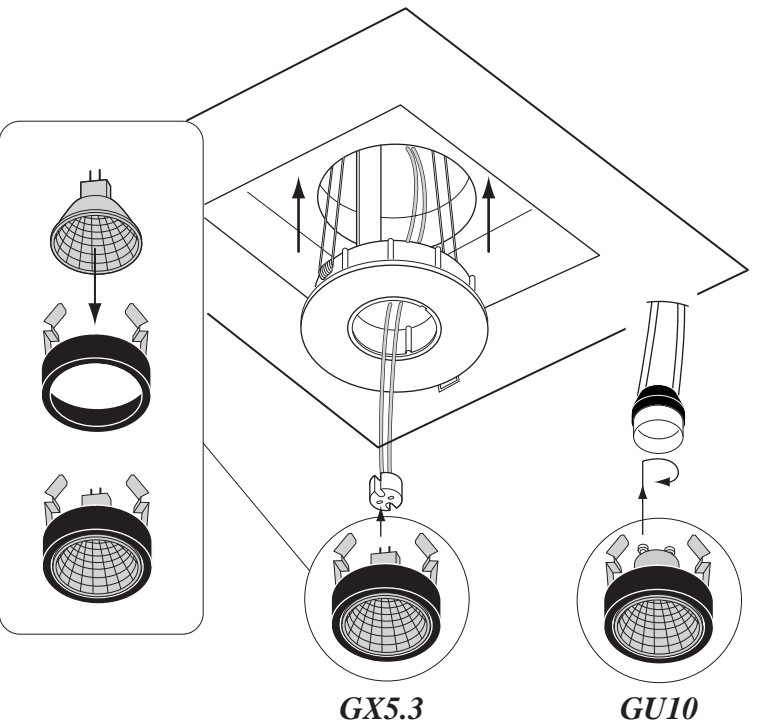

GX5.3 **GU10**

Cablage LED

230-240V

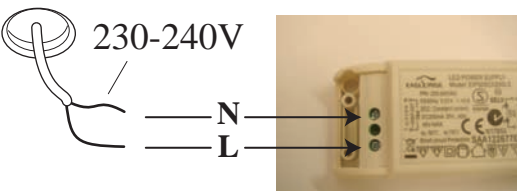

5

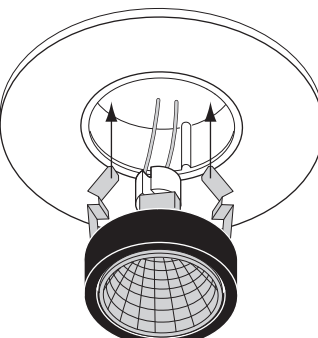

6 *Changement de l'ampoule*
Replacing lamp

