



SOLE

PENDANT LIGHT



KEY FEATURES

- Suspended plaster pendant for indirect ambient lighting
- High strength reinforced natural gypsum plaster from France
- Indirect lighting in 3000K colour temperature (warm white)
- A range of dimming/control options including Fixed Output, 1-10V, DALI, Push-Dim or Casambi control
- Integrated Medium Power COB LED, CRI 80+
- Natural plaster finish can be painted on-site, or supplied with Acrylic White, Metallic or Matt Polyurethane Lacquer finishes



atelier sedap **CASAMBI**

**60 YEARS
IN LIGHT**

CALL: +44 (0) 1235 55 37 69

EMAIL: sales@optelma.co.uk

ISSUE DATE: 13/01/21

HEAD OFFICE

The Science Park
Abingdon
Oxfordshire OX14 3YT
United Kingdom

SHOWROOM

23 Bowling Green Lane
Clerkenwell
London EC1R 0BD
United Kingdom

FRANCE

28 Rue Charles
Baudelaire
75012 Paris
France

SWITZERLAND

St. Urbangasse 53
Postfach 1738
CH-4502 Solothurn
Switzerland

SOLE PENDANT SPECIFICATIONS

PRODUCT OPTIONS	
Dimensions (mm):	500 - 1200 (Ø) x 80 - 160 (D)
Cut-out (mm):	N/A
Weight (kg):	2.9 - 15 kg
Lifetime:	50,000 hrs
Mounting type:	Suspended Parallel
Finish:	Natural Plaster (ceiling rose: Matt White)
Emergency:	N/A (Separate Emergency lighting products available on request)
Operating voltage:	230V
IP Rating:	IP20
Light source:	Medium Power COB LED
Driver:	Fixed Output, 1-10V, DALI, Push-dim, Casambi control*
Colour temperature:	3000K
Beam Angle:	N/A
Diffuser:	N/A
CRI:	80+
Optional Extras:	Plaster-in Hatch for remote driver access and alternative finishes

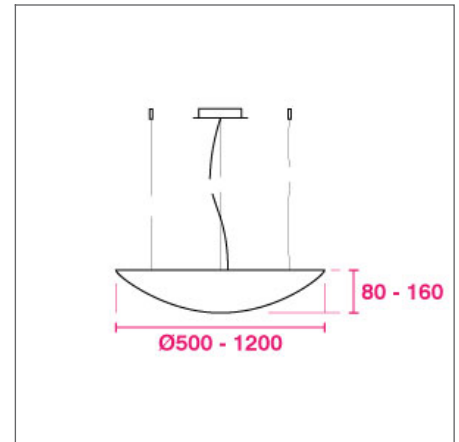

SOLE DIMENSIONS (MM)

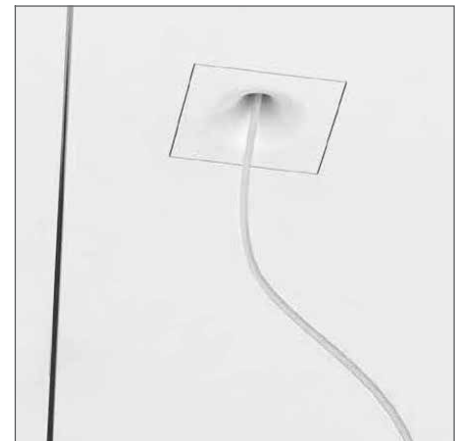

PLASTER-IN HATCH FOR REMOTE DRIVER

SELECT A SIZE AND POWER TO SUIT YOUR PROJECT

Size/Depth (mm)	Source Lumens	Power (W)	Weight
Ø 500 x 80 (D)	3750 lm	30.0 W	2.9 kg
Ø 600 x 80 (D)	3750 lm	30.0 W	9.0 kg
Ø 800 x 106 (D)	3750 lm	30.0 W	10 kg
Ø 1000 x 133 (D)	3750 lm	30.0 W	13 kg
Ø 1200 x 160 (D)	3750 lm	30.0 W	15 kg

* Parallel wire suspensions only. Compatible with the Plaster-in Hatch.

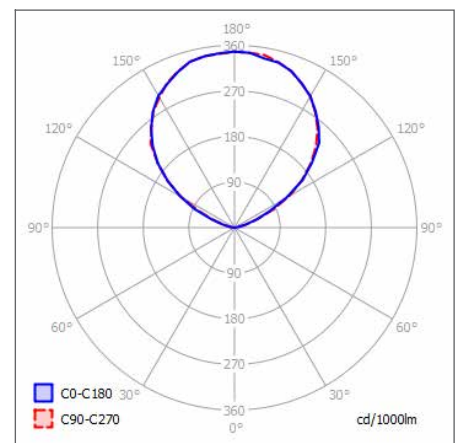

POLAR CURVE 4000K COB LED



atelier sedap **CASAMBI**

**60 YEARS
IN LIGHT**

CALL: +44 (0) 1235 55 37 69
EMAIL: sales@optelma.co.uk
ISSUE DATE: 13/01/21

HEAD OFFICE
The Science Park
Abingdon
Oxfordshire OX14 3YT
United Kingdom

SHOWROOM
23 Bowling Green Lane
Clerkenwell
London EC1R 0BD
United Kingdom

FRANCE
28 Rue Charles
Baudelaire
75012 Paris
France

SWITZERLAND
St. Urbangasse 53
Postfach 1738
CH-4502 Solothurn
Switzerland

SOLE PENDANT COMPONENTS



**NATURAL
PLASTER**

Made from high-strength plaster.

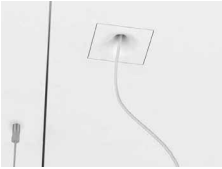

**PLASTER-IN
HATCH**

For easy driver maintenance and clean ceilings.

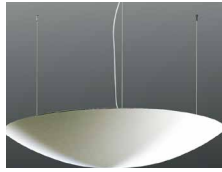

**PARALLEL WIRE
SUSPENSION**

Steel wire suspension for LED versions only.



**MATT
POLYURETHANE
LACQUER**

Vibrant custom painted finishes.



CEILING ROSE

Powder-coated Matt
White ceiling rose.



**METALLIC
PAINTS**

Metal custom painted finishes.



atelier sedap **CASAMBI**

**60 YEARS
IN LIGHT**

CALL: +44 (0) 1235 55 37 69
EMAIL: sales@optelma.co.uk

ISSUE DATE: 13/01/21

HEAD OFFICE

The Science Park
Abingdon
Oxfordshire OX14 3YT
United Kingdom

SHOWROOM

23 Bowling Green Lane
Clerkenwell
London EC1R 0BD
United Kingdom

FRANCE

28 Rue Charles
Baudelaire
75012 Paris
France

SWITZERLAND

St. Urbangasse 53
Postfach 1738
CH-4502 Solothurn
Switzerland

SOLE PENDANT SPECIFICATION CODE

AAAA - BB/C/D/E - F/GGG - HHHH/I								
AAAA PRODUCT ID	BB MOUNTING	C FINISH	D DRIVER	E DIFFUSER	F INDIRECT LED	GGG CRI / COLOUR	HHH DIAMETER / SIZE (mm)	I EMERGENCY
SOLE	SP X*	P	F 1 D P C	N	M	830	500 600 800 1000 1200	

- * **X** Custom Options - specify details alongside code
- PRODUCT ID **SOLE** Sole Indirect pendant
 - MOUNTING **SP** Suspended Parallel
 - FINISH **P** Natural Plaster
 - DRIVER **F** Fixed Output, **1** 1-10V Dimming, **D** DALI, **P** Push Dim, **C** Casambi
 - DIFFUSER **N** None (N/A)
 - DIRECT LED **M** Medium Power COB LED
 - CRI / COLOUR **830** CRI 80+ Colour 3000K
 - DIAMETER / SIZE Size in millimetres
 - EMERGENCY No emergency options available

STANDARD

Standard fixed option products for quick and easy specification. Point source LED and Linear LED solutions, organised into Track & Spots, Downlights, Recessed, Surface, Suspended and Wall mounted solutions.

MADE-TO-MEASURE

Versatile systems and luminaires with custom specifications for project-specific lighting. Available in custom sizes and lengths, with many options including curves, corners, finishes, integrated accessories and more.

BESPOKE

Bespoke luminaires demonstrating completely custom project solutions, designed with the clients from concept to delivery. Learn about the design process and inspire your next bespoke lighting project.



atelier sedap **CASAMBI**

**60 YEARS
IN LIGHT**

CALL: +44 (0) 1235 55 37 69
EMAIL: sales@optelma.co.uk
ISSUE DATE: 13/01/21

HEAD OFFICE

The Science Park
Abingdon
Oxfordshire OX14 3YT
United Kingdom

SHOWROOM

23 Bowling Green Lane
Clerkenwell
London EC1R 0BD
United Kingdom

FRANCE

28 Rue Charles
Baudelaire
75012 Paris
France

SWITZERLAND

St. Urbangasse 53
Postfach 1738
CH-4502 Solothurn
Switzerland